



### PRODUCT FEATURES

- Direct mount to door frame for strength and reliability
- Compact design fits tight spaces
- Fully sealed for weatherproof operations
- Sealed 6 ft. [1.8m] jacketed, stranded conductor cable
- Instant release circuit - no residual magnetism
- Efficient, low-voltage, low power usage
- All ferrous metal surfaces plated for durability and rust resistance
- MagnaCare Lifetime Replacement No Fault Warranty

### SPECIFICATIONS

- UL 10C Listed
- CAN4-S104, CAN/ULC-S533 Listed
- ANSI/UL 294 Listed
- ANSI/BHMA 156.23, Grade 1; E08571-1000, E08581-1000

- CSFM - California State Fire Marshal Approved
- CE:EN 50091-1, EN 61000-6-2 Approved
- NEMA: 4X
- IEC: IP66
- Patent numbers: 6,007,119; 6,135,515

#### Holding Force:

600lbs [272kg]

#### Dimensions:

7-3/16" L x 1-1/8" D x 1" H

#### Electrical

62mA at 24VDC only

#### Operating Temperature

-40 to +140F [-40 to +60C]  
Indoor or outdoor use  
Not for use in open channel doors

#### Shipping Weight:

2.5lbs [1.13kg]

#### Finishes:

US32D/630 - Satin Stainless Steel

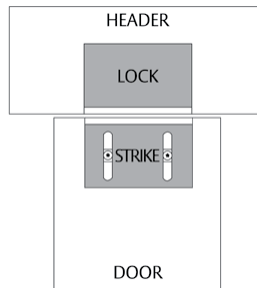

# SAM2-24

## Shear Aligning Magnalock®

### Strong Hold for Better Asset Management

The compact, concealed SAM2-24 Shear Aligning Magnalock provides 600lbs of holding force to swinging doors or sliding doors. The discreet SAM 2-24 mounts fully concealed and is ideally suited to secure smaller applications, like sliding closet doors, atriums, and more.

### » MODELS

PART # | Description

SAM2-24 | Shear Magnalock - 24VDC, Mini Version

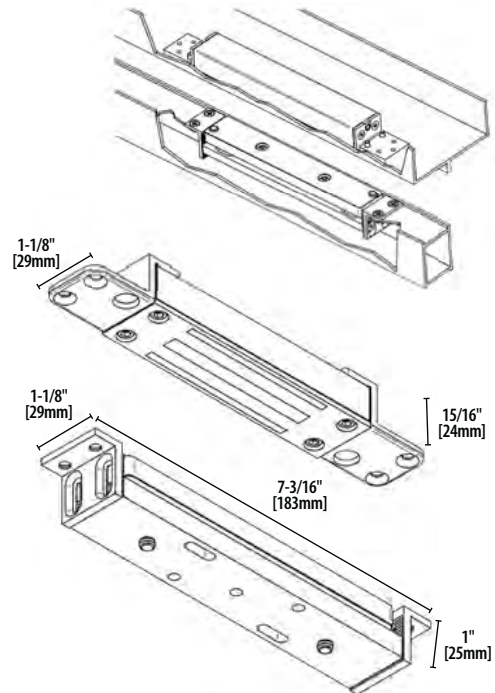

SECURITRON®

ASSA ABLOY