

BHMA Certification Program

This program was developed to establish product classifications through performance testing. Three grades (1, 2 and 3) of product classifications were established for continuous hinges, with three weight groups (150, 300 and 600) for each grade: Grade 3 being the lowest and Grade 1 being the highest classification. Each classification and weight group has a set of established cycle requirements and wear characteristics, with a minimum for vertical and lateral wear to establish a listing under a weight and grade classification, after the set number of cycles is completed.

Maximum Vertical Wear Allowable:

- Grade 3 = 0.105"
- Grade 2 = 0.030"
- Grade 1 = 0.020"



Maximum Lateral Wear Allowable:

- All Grades = 0.062"

Cycle requirements range from Grade 3-600 requiring 100,000 cycles through Grade 1-150 requiring 2.5 million cycles.

For more information on certification testing or other product certification programs, please contact PEMKO Customer Service.

Hospital Tip

A special modification is available for certain hinges which provides an extra bearing at the top of the gear cap, leaving no opening. A 45° angled cut on the gear cap and leaf covers provides a safe environment for hospitals and correctional facilities.

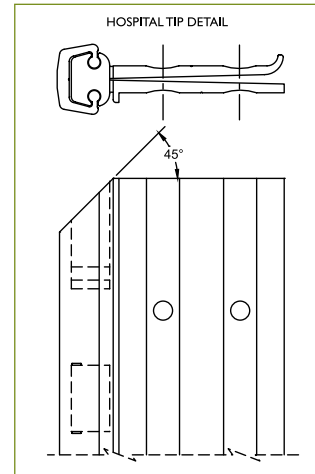

Cycle Requirements - Per BHMA Standard ANSI/BHMA A156.26-2006

- Standard Duty Hinges (excluding _RS175 & _RS138) conform to Grade 3-150 and Grade 3-300
- HD3 Hinges conform to Grade 3-150, Grade 3-300, and Grade 3-600
- HD1 Hinges conform to Grade 2-150, Grade 1-300, and Grade 1-600
- 1100 Series and X-Series Hinges conform to Grade 1-150

Weight Bearing - Per BHMA Standard ANSI/BHMA A156.26-2006

- This information pertains to all commercial models
- Heavier weight can be carried; please contact Customer Service for applications other than those listed in the chart
- Special hinge reinforcements are not required as hollow metal door and frame manufacturers' standard are acceptable. Removal of hinge reinforcements in the door and frame is not advised. Hinge preps must have fillers installed

	Hinge Size	Number of Bearings	Door Weight
Residential Hinges	79" and 83"	7	90 lbs.
Standard Duty Hinges	83" and 85"	14	280 lbs.
	95"	16	320 lbs.
	120"	20	400 lbs.
Heavy Duty (HD1 & HD3) Hinges	83" and 85"	27	540 lbs.
	95"	31	620 lbs.
	120"	39	780 lbs.

UL Fire Labeled 3-Hour



- All models designated with these symbols are tested and certified by Underwriters Laboratories Inc.® (U.S.A. and Canada) to standards UL10B, UL10C and UBC7.2 (positive pressure) for up to and including a 3-Hour Fire Listing for all 4'0" x 10'0" and 8'0" x 10'0" door and frame assemblies. Fire listing certifications apply to all approved hollow metal and wood door assemblies in drywall or masonry wall construction
- Special FirePins™ are only required on 3-Hour assemblies. Please refer to page PH-15 for illustrations and information regarding the application of PEMKO FirePins™

- All hinges are supplied with standard fastener kits. Replacement kits/individual fasteners may be purchased separately
- TEK/TORX fasteners may be purchased separately. Full-mortise hinges require 40 each; half-surface hinges require 20 each; full-surface hinges require 12 each
- All half-surface and full-surface hinges are supplied with a snap cover for the door leaf. Replacement snap covers may be purchased separately
- Rain caps may be purchased separately